



## BRAD – PULLEY BLOCKS

### FRAME:

Rugged steel frame shaped to occupy minimum headroom, ensures permanent alignment of spindles and gears, encloses and protects the load chain wheel. Detachable steel cover totally encloses the gears. Hand chain wheel cover protects the hand chain wheel and brake unit.

### HOOKS:

Hooks are of forged alloy steel. Top hook swivels on balls housed in cross head. For chain hoist on single fall of chain, bottom hook rotates on balls housed in a cross head swivel. For chain hoists with 2 falls the bottom hook rotates on balls housed in hook holders and is supported by bottom block frame.

### SAFETY LATCH:

Every bottom hook is equipped with a safety latch a safety latch for top hook is an optional attachment.

### LOAD CHAIN WHEEL:

Made from spheroidal graphite iron, has pockets accurately cast to receive calibrated load chain. Bottom Block wheel for chain hoists with two falls are fitted with needle rollers.

### LOAD CHAIN:

Alloy steel Grade 80 to international standards. All chains are electrically resistance welded and heat treated to give ductility, toughness and wear resistance. Accurately calibrated, pitched and polished to ensure free movement. Each link is tested to twice the safe working load and can withstand shock loads.

## GEARS:

All gears are accurately machine cut from alloy steel and case hardened to ensure long life.

## BEARINGS:

Load wheel mounted on needle rollers housed in bush bearing thus reducing effort required for hoisting.

## LOAD BRAKE:

The precision self-actuating screw disc type mechanical brake engages instantly and provides uniform performance with rated capacity. When lowering a load is under perfect control at all times, that is exceptionally valuable where accurate movement is demanded for spotting loads. Ratchet wheels are hardened and surfaces ground to maintain parallelism with adequate thickness to engage properly with pawl.

## HAND CHAIN WHEEL:

Hand chain wheel having bore with multistart threading and pockets accurately cast to receive calibrated hand chain. Hand chain wheel cover prevents chain from snagging fouling.

## TEST :

BRAD hand chain hoist are tested for 50% overload at works in support of which test certificates are issued.

# BRAD HAND CHAIN HOISTS

Dimension, Weights and performance date

CAPACITY (SAFE WORKING LOAD)		T	0.5	1.0	1.5	2.0	3.0	5.0
NO. OF FALLS OF LOAD CHAIN			1	1	1	2	2	2
TEST LOAD		T	0.75	1.50	2.25	3.00	4.50	7.50
PULLING EFFORT ON HAND CHAIN		KG	16	32	37	32	38	42
WT. FOR STD. 3 MTR. CLEAR LIFT		KG	10.5	11	16.0	15.5	24	36
ADDITIONAL WT. FOR EXTRA MTR.LIFT		KG	1.7	1.7	2.3	2.5	3.7	5.3
TRACK WIDTH RANGE I		MM	75-125	75-125	80-140	80-140	80-150	100-150
TRACK WIDTH RANGE II		MM	140-180	140-180	150-210	150-210	180-210	180-210
MINIMUM DEPTH OF TRACK		MM	125	125	150	150	150	200
MINIMUM RADIUS OF TRACK CURVE		MM	1500	1500	2000	2000	2000	2500
Major Dimensions (approx.)	A (HEAD ROOM) HOOK SUSPENSION	MM	280	300	360	380	470	600
	HUNG IN TROLLEY	MM	384	404	490	510	605	755
	B	MM	142	142	178	142	178	210
	C	MM	126	126	142	126	142	165

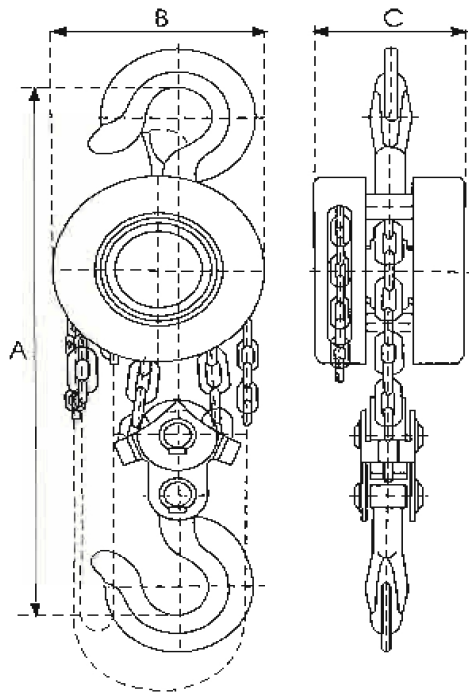

AS 2t AS3t AS5t

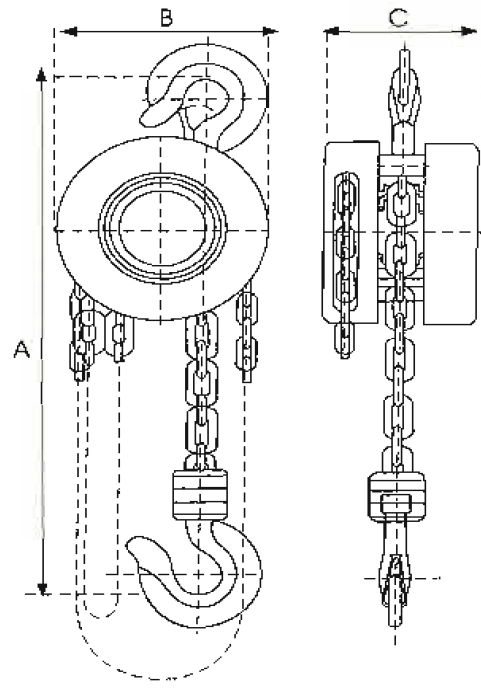

AS 1/2t AS1t AS1/2t